

Datasheet

oToBrite Electronics, Inc



oToCAM271-C110M

1. General Description

The oToCAM271-C110M is an automotive grade camera for the application of autonomous driving system. It uses high sensitive CMOS sensor to perform good image quality for the detection purpose of the system product.

2. Product specification

No.	Item	Specification
1	Image sensor	IMX728
2	Optical Format	8M
3	Pixel Size	2.1um x 2.1um
4	Camera number of pixels	3856(H) x 2176(V)
5	View angle(H)	110°
6	Resolution (Center/Corner)	TBD
7	Color filter array	RGGB
8	Output Interface	GMSL2 with POC
9	Output Formats	12bit raw data (default setting)
10	S/N ratio	46.3 dB
11	Lens structure	3GM+4G
12	Lens F No.	F1.6
13	Power source (POC)/Typical	DC6V-12V/12V
14	Startup time of power in	Within 200ms
15	Frame rate (default)	30fps (default setting)
16	Serializer	MAX9295
17	Camera Current Consumption	≤ 150mA @12V/25°C
18	Operating Temperature	-40°C ~ +85°C
19	Storage temperature Range	-40°C ~ +95°C
20	Waterproof	IP 67/IP 69K
21	Dimension(mm)	28*28*64.3 mm (exclude Fakra connector)
22	Weight	55.4g

3. Outline Drawing

3.1 Outline Drawing (with bracket)

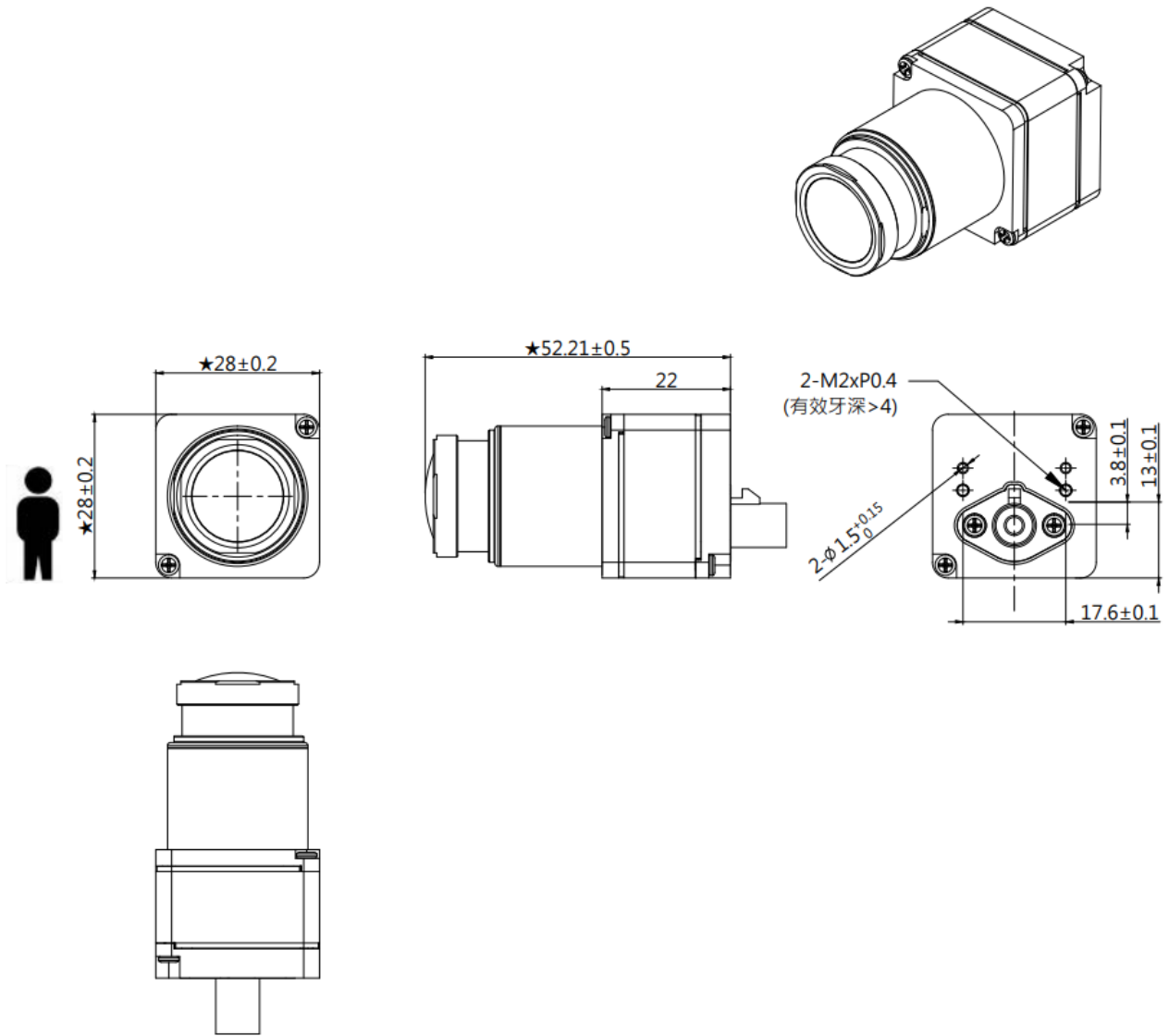

Figure 2. oToCAM271-C110M Diagram

4. Interface, Cables and Connectors

4.1 Connectors: Goldenconn Electronic Technology Co., Ltd. 1FABN24F01PNTV00

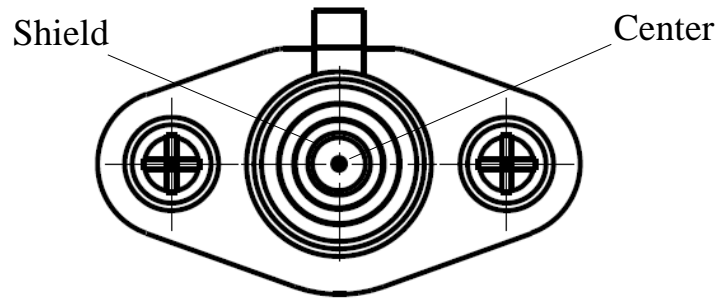

Figure 2. Goldenconn Electronic Technology Co., Ltd. 1FABN24F01PNTV00

4.2. Pin definition:

Pin No.	Signal Name	Operation Voltage and Current
Center	DOUT	Min. 0.3V, Max. 0.5V
	PWR	Typ. 115mA @12V / 25°C
Shield	Shield GND	

5. Applications

5.1. I2C ID Address

oToCAM271



5.2. Initialization

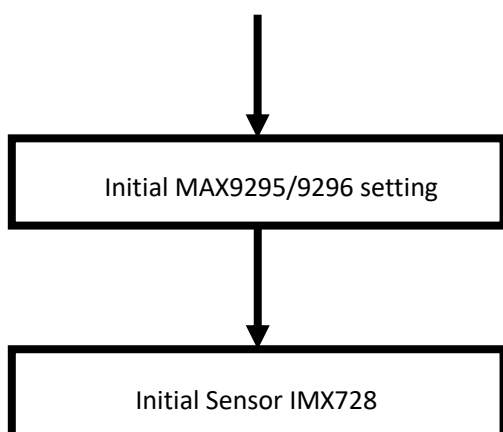

5.3. Deserializer (MAX9296) Settings

(The registers file will be provided under NDA and/or samples purchased)

5.4. Sensor (IMX728) Register Settings

(The sensor registers file will be provided under NDA and/or samples purchased)

6. Special Note

There is no ISP (Image Signal Processor) inside this camera. Raw image data 12bits are captured and transmitted from camera through coax cable.

Usually, Gamma curve is applied to get 8-bit image to improve dynamic range for application.

7. System Configuration (TBD)

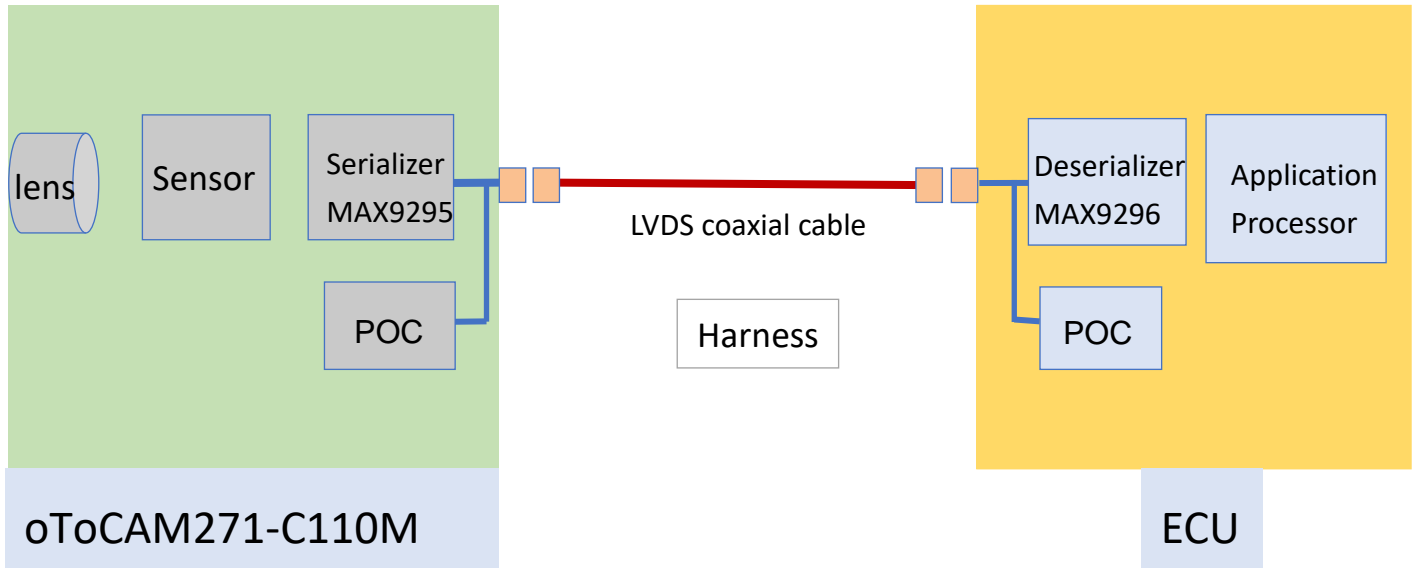

Figure 3. System Configuration

MAX9296 must be used as de-serializer in ECU for connecting oToCAM271-C110M.