

Datasheet

oToBrite Electronics, Inc

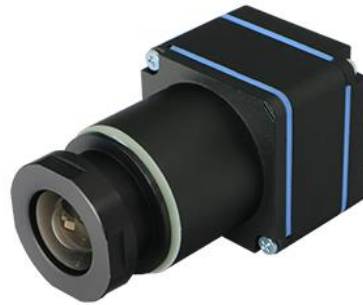

oToCAM266-C60M

1. General Description

The oToCAM266-C60M is an automotive grade camera for the application of autonomous driving system. It uses high sensitive CMOS sensor to perform good image quality for the detection purpose of the system product.

2. Product specification

No.	Item	Specification
1	Image sensor	CMOS (On-Semi AR0820)
2	Optical Format	1/2"
3	Pixel Size	2.1 μ m (H) \times 2.1 μ m (V)
4	Camera Resolution (default)	8.3M (3848(H) \times 2168 (V))(default setting)
5	View angle(H)	58.3°
6	Resolution (Center/Corner)	IH0 SFR \geq TBD, IH8 SFR \geq TBD @imatest (120 lp/mm)TBD
7	Color filter array	RGGB
8	Output Interface	GMSL2 with POC
9	Output Formats	12-bit raw data (default setting)
10	S/N ratio	41.8 dB
11	Lens F No.	F1.7
12	Power source (POC)/Typical	DC6~12V/6V (TBD)
13	Startup time of power in	Within 200ms
14	Frame rate (default)	30 fps (default setting)
15	Exposure Control	N/A
16	Serializer	MAX9295
17	Camera Current Consumption	\leq 102 mA @12V
18	Operating Temperature	-40°C ~ +85°C
19	Storage temperature Range	-40°C ~ +95°C
20	Waterproof	IP 67/IP 69K
21	Dimension(mm)	28*28*52.2
22	Product Lead Time	Sample: 1 month after getting firm order SOP: 1 months after getting firm order (assumption: customer has released 6 months rolling forecast)

3. Outline Drawing

3.1 Outline Drawing

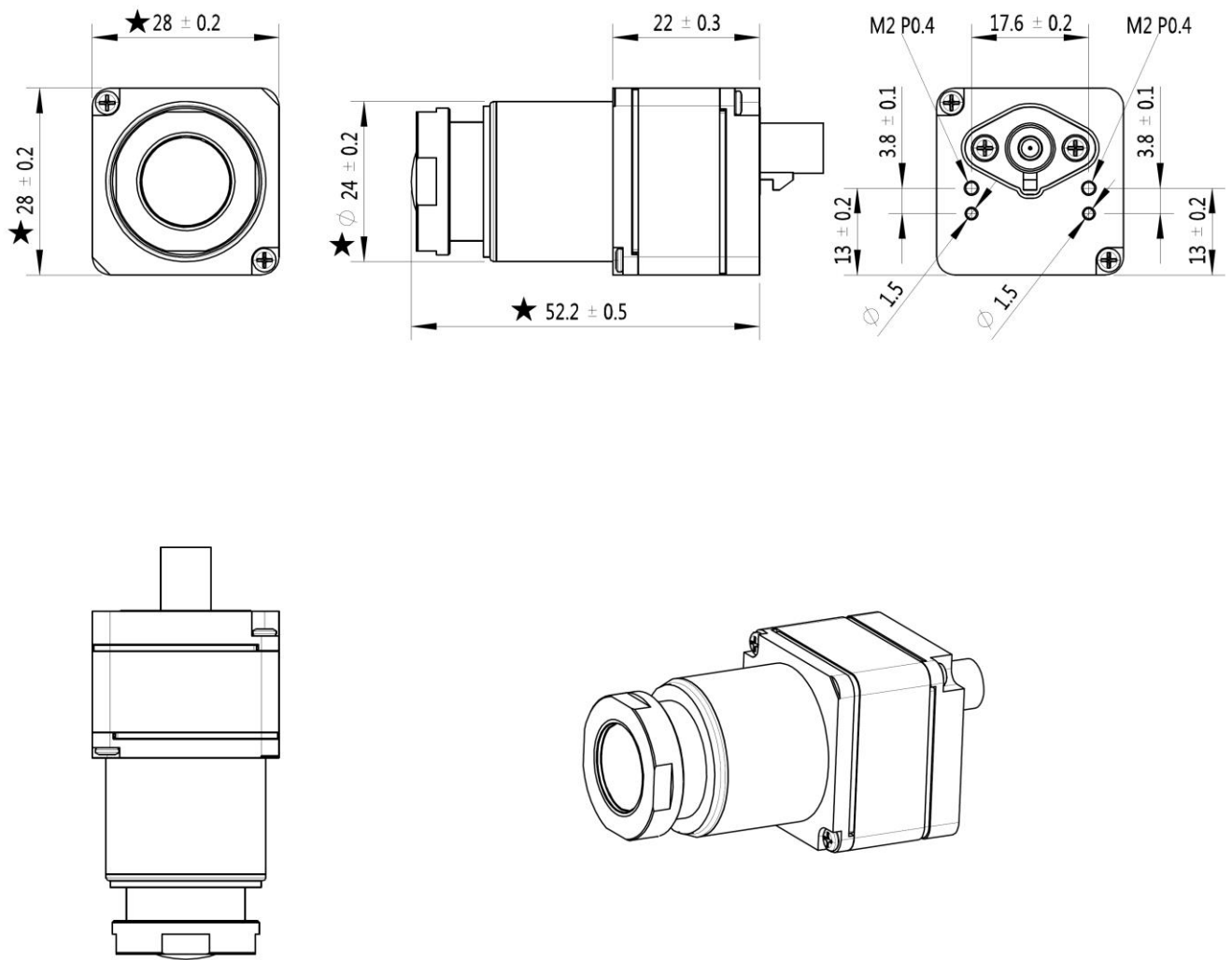

Figure 2. oToCAM266-C60M Diagram

4. Interface, Cables and Connectors

4.1 Connectors: Amphenol SMB1251Y3-002-TT5GP-50

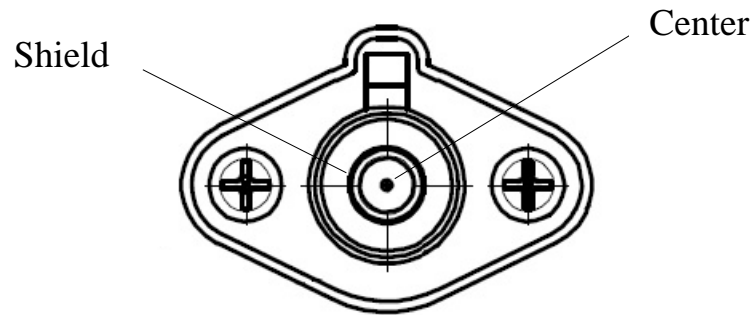

Figure 2. Amphenol SMB1251Y3-002-TT5GP-50

4.2. Pin definition:

Pin No.	Signal Name	Operation Voltage and Current
Center	DOUT	Min. 0.3V, Max. 0.5V
	PWR	Typ. 202mA @6V / 25°C
Shield	Shield GND	

5. Applications

5.1. I2C ID Address (AR0820)

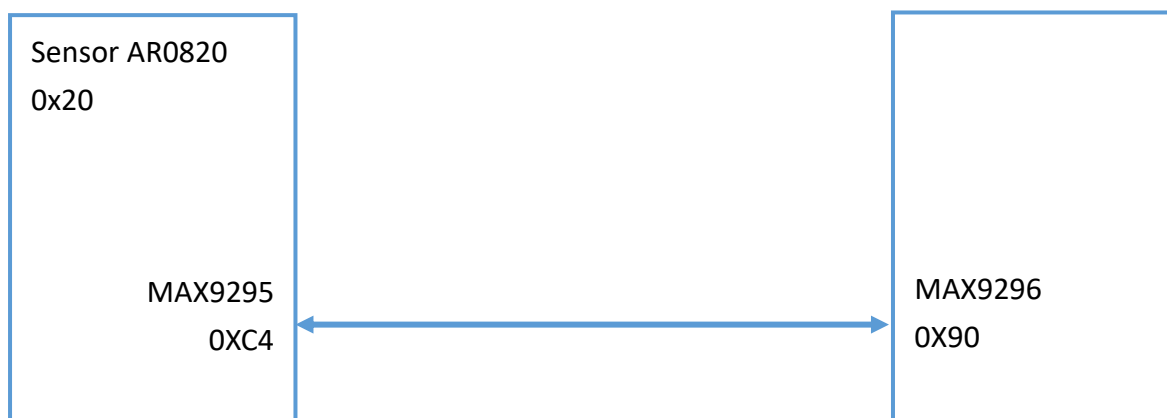

5.2. Initialization

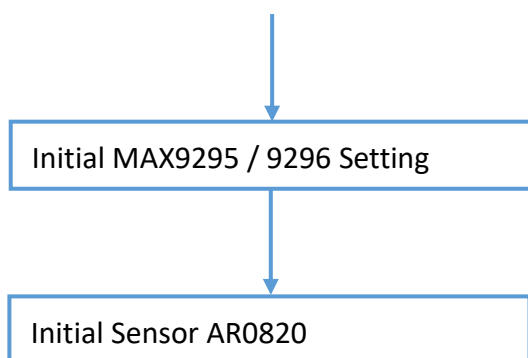

5.3. Deserializer (Maxim 9296) Settings

(The registers file will be provided under NDA and/or samples purchased)

5.4. Sensor (AR0820) Register Settings

(The sensor registers file will be provided under NDA and/or samples purchased)

6. Special Note

There is no ISP (Image Signal Processor) inside this camera. Raw image data 12bits are captured and transmitted from camera through coax cable.

Usually, Gamma curve is applied to get 8-bit image to improve dynamic range for application.

7. System Configuration (TBD)

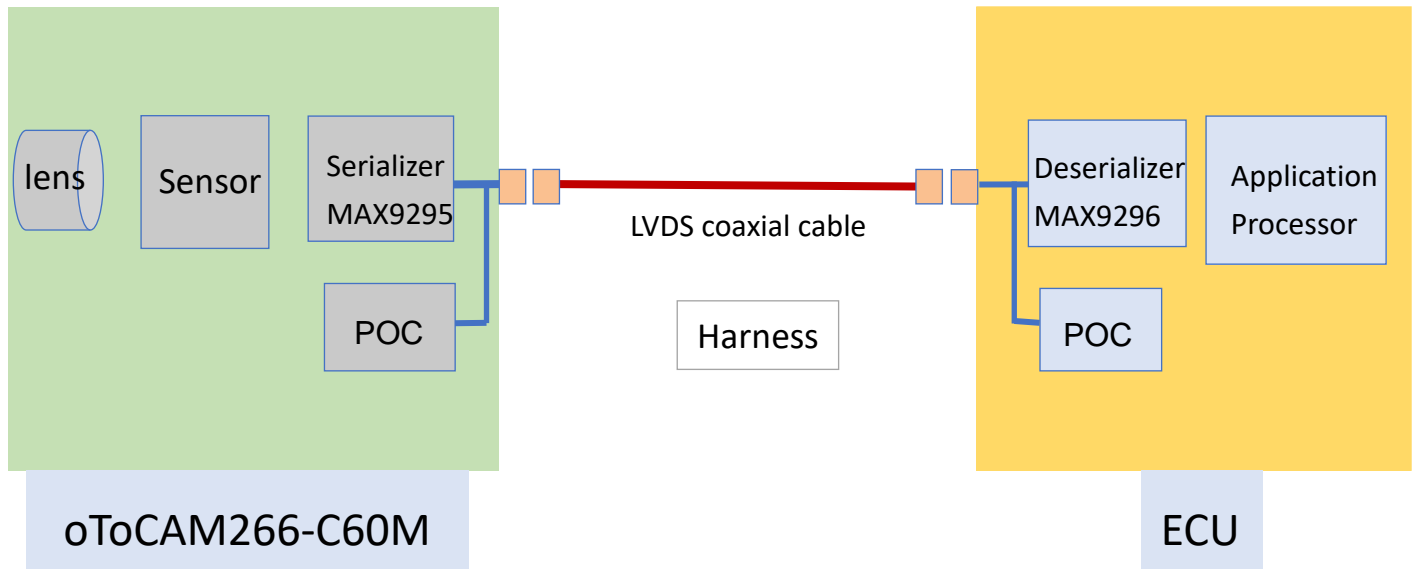

Figure 3. System Configuration

Maxim MAX9296 must be used as deserializer in ECU for connecting oToCAM266-C60M.