

oToBrite



Automotive Camera



oToCAM251 (VB56G4A)

Overview

The oToCAM251 is an advanced automotive Driver Monitoring Camera (DMC) designed for in-cabin applications. It features a highly sensitive 1/4" monochrome CMOS sensor and is equipped with two 940nm infrared LEDs, making it an ideal choice for enhancing driver monitoring capabilities in automotive environments.

Specifications

• General Specifications

Item	Specifications
Image sensor	ST VB56G4A
HDR	N/A
Camera output pixel number	Mega-pixel 1120(H) x 1364(V)
Initial code resolution	1088(H) x 1080(V)
View angle (H)	31°
Resolution (Center/Corner)	TBD
Color filter array	Mono
Output interface	FPD-Link III with POC
Output formats	10-bit raw data
Lens F No.	F2.05
DOF/ Object distance	0.7~1.1M@90cm
Power source (POC)/ Typical	DC 12V
Startup time of power in	Within 200ms (not include loading time)
Frame rate	30 fps (default setting)
Connector	Goldenconn Electronic Technology Co., Ltd. 1FABN24F01PNTV00
Exposure control	External AE
Serializer	TI DS90UB953
Camera current consumption	Average 120mA @12V Peak 890mA @12V (by initial setting)
LED	Two IR (940nm) LEDs
LED power	Average 0.85W Peak 8.5W (by initial setting)
Operating temperature	-40°C ~ +85°C
Storage temperature range	-40°C ~ +95°C
Dust & Waterproof	N/A
Dimension	44.2x32x25.8mm (exclude Fakra connector)
Weight	46.5g

Outline Drawing

- oToCAM251 Mechanical Dimensions

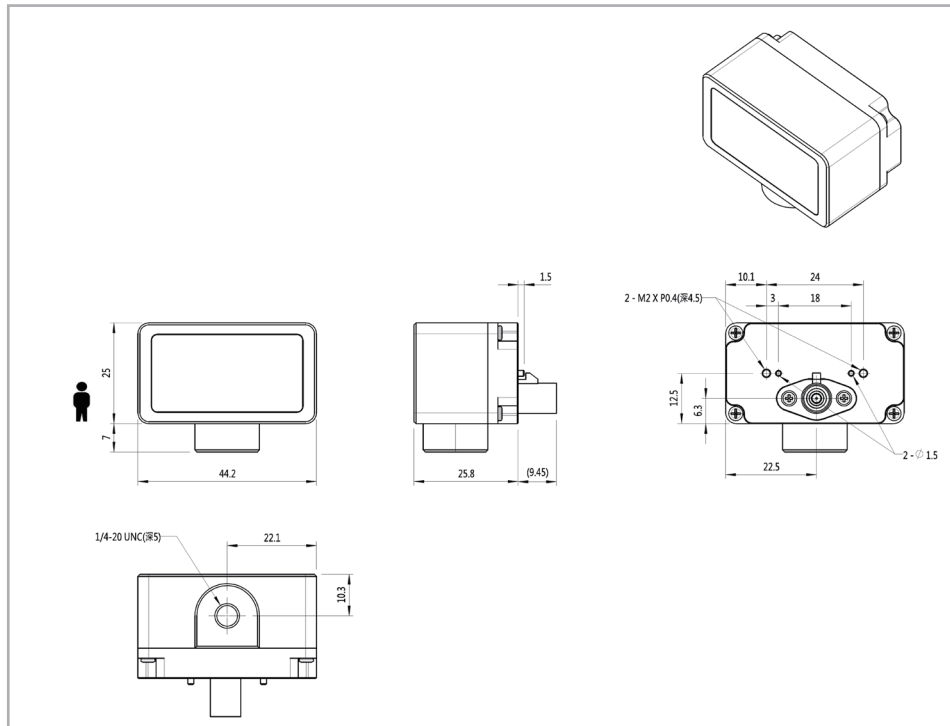

driving easier and safer



6F, No.18, Prosperity Rd.II, Science-Based Industrial Park,
Hsinchu, Taiwan, R.O.C

| +886-(0)3-666-7968

| sales@otobrite.com

| www.otobrite.com