

Datasheet

oToBrite Electronics, Inc



oToCAM264-N73T

<u>Revision</u>	<u>Description</u>	<u>Release Date</u>
1.0	First Release	April, 10, 2020
1.1	Modified typo	Jun. 16. 2020
1.2	Spec update	Jul. 23. 2020

1. General Description

The oToCAM264-N73T is an automotive grade camera for the application of autonomous driving and CMS. It uses high sensitive CMOS sensor to perform good image quality for the detection purpose of the system product.

2. Product specification

No.	Item	Specification
1	Image sensor	CMOS (Sony IMX 390)
2	Optical Format	1/2.7"
3	Pixel Size	3.0 μ m (H) \times 3.0 μ m (V)
4	Camera number of pixels	2M (1920 (H) \times 1080 (V))
5	View angle(H)	73 $^{\circ}$
6	Resolution	TBD
7	Color filter array	RGGB
8	Output Interface	FPD-Link III with POC
9	Output Formats	12-bit raw data (By setting)
10	S/N ratio	48.5 dB
11	Lens structure	All glass
12	Lens F No.	F1.7
13	Power source (POC)/Typical	DC 6~12V/6V
14	Startup time of power in	Within 200ms
15	Frame rate	30 fps (By setting)
16	Serializer	TI953
17	Camera Current Consumption	\leq 150mA @12V
18	Operating Temperature	-40 $^{\circ}$ C ~ +85 $^{\circ}$ C
19	Storage temperature Range	-40 $^{\circ}$ C ~ +95 $^{\circ}$ C
20	Waterproof	N/A (Lens no waterproof design)
21	Dimension	28*28*38.7 mm (exclude Fakra connector)
22	Weight	39.5g
23	Product Lead Time	Sample: 1 month after getting firm order SOP: 1 months after getting firm order (assumption: customer has released 6 months rolling forecast)

3. Outline Drawing

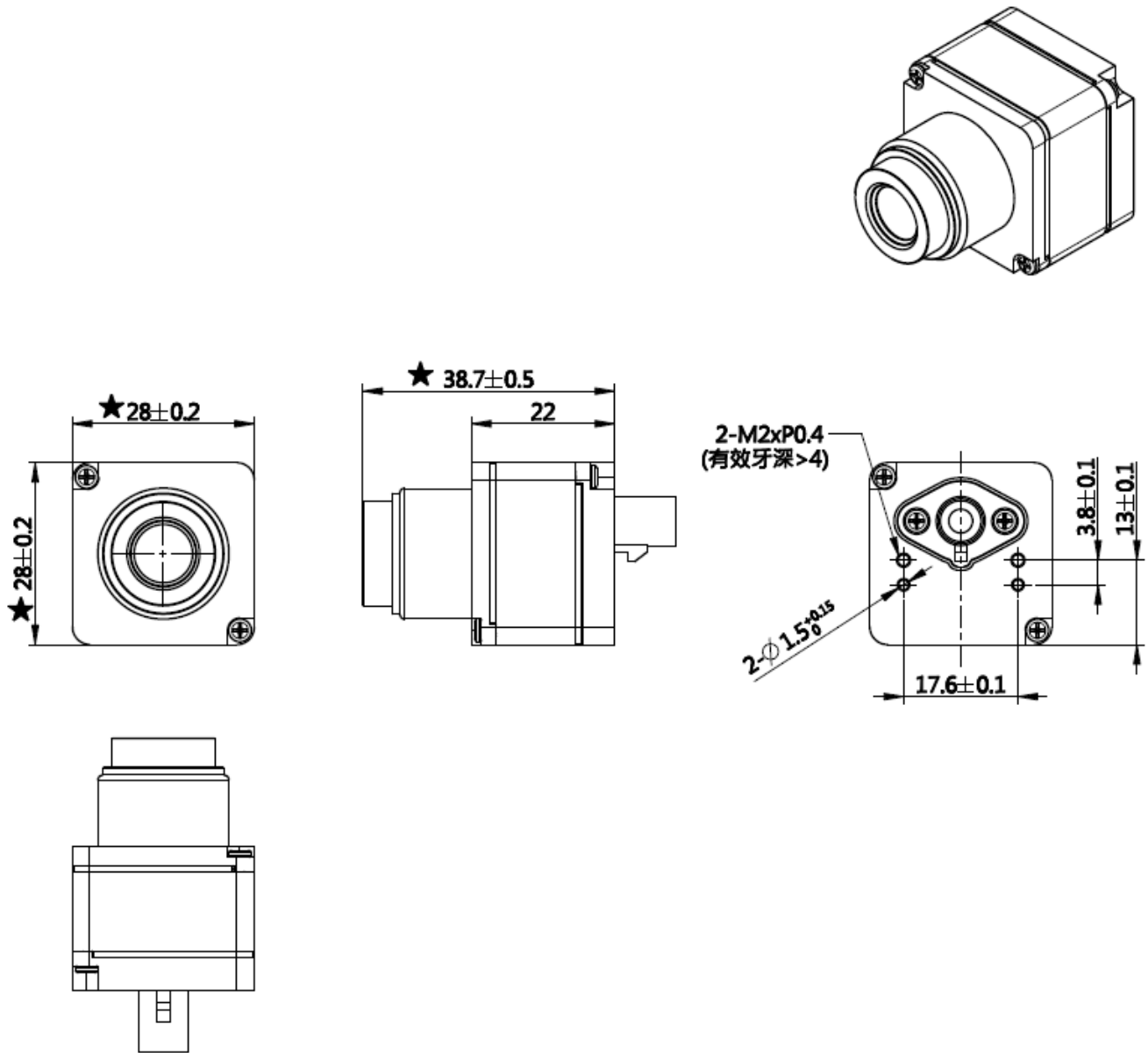

Figure 1. oToCAM264-N73T Diagram

4. Interface, Cables and Connectors (Male and Female)

4.1 Connectors: Amphenol SMB1251Y3-002-TT5GP-50

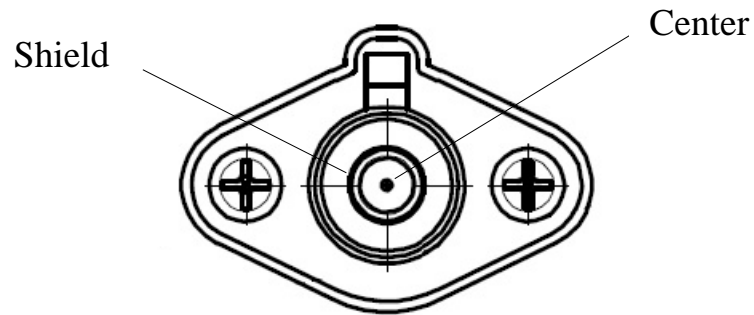

Figure 2. Amphenol SMB1251Y3-002-TT5GP-50

4.2. Pin definition:

Pin No.	Signal Name	Operation Voltage and Current
Center	DOUT	Min. 0.52V, Max. 0.67V
	PWR	Typ. 170mA @6V / 25°C
Shield	Shield GND	

5. Applications

5.1. I2C ID Address

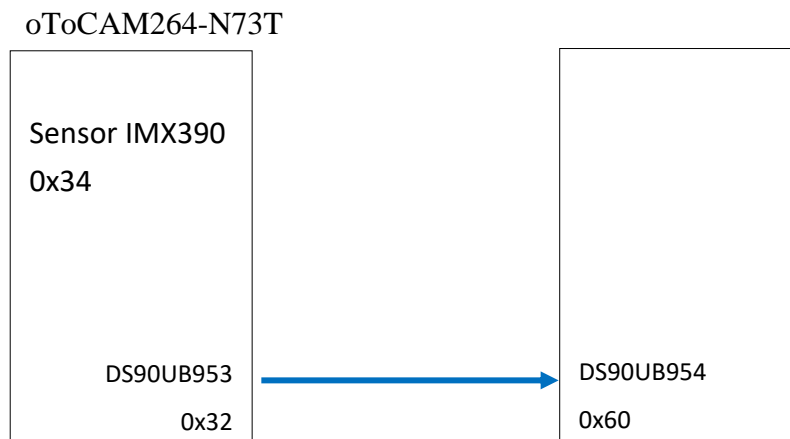

5.2. Initialization

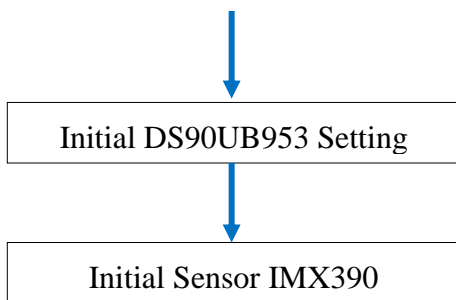

5.3. Deserializer (DS90UB953) Settings

(The registers file will be provided under NDA and/or samples purchased)

5.4. Sensor (IMX390) Register Settings

(The sensor registers file will be provided under NDA and/or samples purchased)

6. Special Note

There is no ISP (Image Signal Processor) inside this camera. Raw image data 12bits are captured and transmitted from camera through coax cable.

Usually, Gamma curve is applied to get 8-bit image to improve dynamic range for application.

7. System Configuration (TBD)

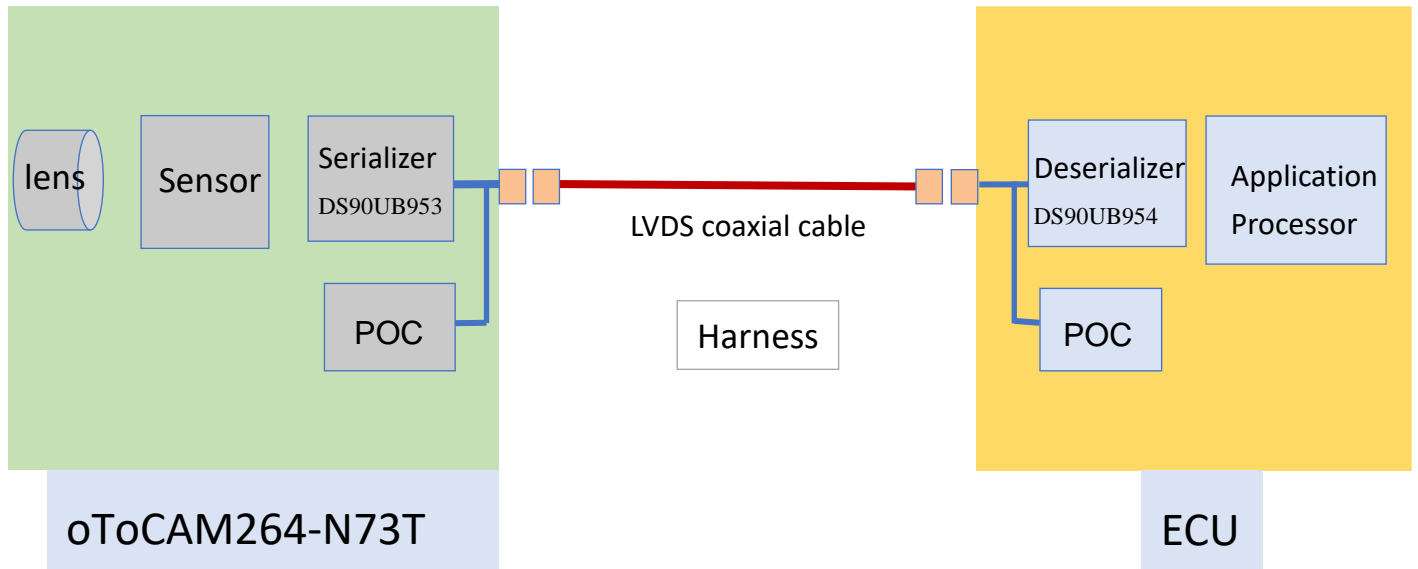

Figure 3. System Configuration

TI953 must be used as de-serializer in ECU for connecting oToCAM264-N73T.